



HAVELLS

QTRON

Moulded Case Circuit Breakers

Efficiency Unleashed: Compact, Safe, Reliable



QT 160 A



ABOUT US

Havells India Limited a leading
Fast-Moving Electrical Goods (FMEG) Company



Over 6000 Professionals

over 17000 dealers and 35 branches
in the country & 15 state-of-the-art
manufacturing plants in India



Care 360

first FMEG Company to offer door
step service via its initiative





Havells India Limited is a Fast-Moving Electrical Goods (FMEG) Company with an extremely strong global presence, thanks to our philosophy of Make in India, extensive distribution network and world class quality. Innovation and quality are the prime objectives at Havells and owing to that, every product we make is designed to meet the latest and most demanding customer needs.

The company started its operations in the 1970s and since then, the company has used a judicious mix of organic growth and inorganic opportunities to boost revenues and scale up business. The company today owns a range of established and prestigious brands like Havells, Lloyd, Crabtree and Standard that are sold through its extensive network of dealers and retailers spread across the country. Havells has 12 state-of-the-art manufacturing units in the country located at Haridwar, Baddi, Sahibabad, Sricity, Alwar and Neemrana. These units manufacture globally acclaimed products, synonymous with excellence and precision.

Havells is a major power distribution equipment manufacturer with a strong global presence. Havells enjoys enviable market dominance across a wide spectrum of products including Industrial & Domestic Circuit Protection Devices, Cables & Wires, Motors, Fans, Modular Switches, Home Appliances, Air Conditioners, Electric Water Heaters, Power Capacitors, Luminaires for Domestic, Commercial and Industrial Applications.



HAVELLS MILESTONES

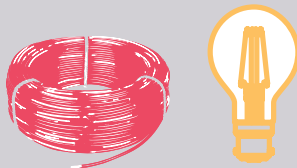

- Havells Acquired Towers and Transformers Ltd and turned it into a Profitably Manufacturing Energy Meters Company in a year.
- Havells started manufacturing MCBs with Geyer, Germany, at Badli, Delhi
- Havells Setup Changeover Switches Manufacturing Plant at Sahibabad, UP
- Havells Setup Control gear – Products Manufacturing Plant at Faridabad, Haryana. Havells was listed on The Bombay Stock Exchange (BSE) and the National Stock Exchange (NSE).
- Havells acquired a Manufacturing Plant of Wires nad Cables from Surya Cables, at Alwar, Rajasthan
- Havells acquired Electric Control and Switchboards at Noida, UP for Manufacturing Customized Packaged Solutions
- Havells Introduced Ferraris High-end Meter in Joint Venture with DZG, Germany



1958-1980

- Commenced trading operations in Delhi
- Acquired HAVELLS brand
- Set up the manufacturing plant for Rewireable Switches and Changeover Switches at Kirti Nagar, Delhi
- Set up a manufacturing plant for HBC Fuses at Badli, Delhi
- Started manufacturing high quality Energy Meters at Tilak Nagar, Delhi



1983-1998

2000-2004

- Havells Acquired Controlling stake in Duke Arnics Electronics (P) Ltd engaged in manufacturing of Electronic Meters.
- Havells acquired controlling interest in an Industry Major – Standard Electronics Ltd.
- Acquired Business of Havells Industries Ltd.
- Standard Electrical Company becomes a 100% subsidiary of Havells.
- Havells Launched Fans, CFL and Lighting.
- Havells setup a domestic switchgear manufacturing plant at Baddi, HP

2005-2007

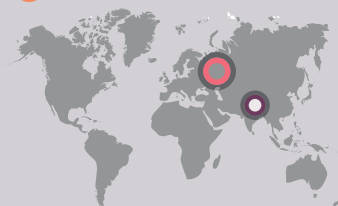

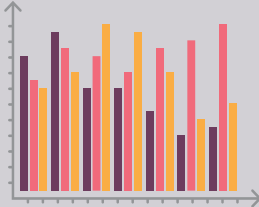

- Havells setup Fans Manufacturing Plant in Haridwar.
- Havells added CFL production Unit in Haridwar Manufacturing Plant
- Havells setup Capacitor Manufacturing Plant



- Havells launched new range of Control gear Cosmic Star Series
- Havells setup India's first and only large-scale Lighting fixture plant in Neemrana.
- Havells setup First private Cables and Wire Testing Facility at Alwar Plant
- Havells introduced Premium fans category under the Standard Brand
- Havells pledges to build eco-friendly and sustainable toilets in 300 schools.

2008-2010

2011-2015

2016-2023

- Havells setup of fully automatic plant for motors in a J.V. with Lafert of Spain in Neemrana.
- Havells setup fully automatic second unit for Switchgear manufacturing in Baddi
- Havells setup second unit for Fan Manufacturing in Haridwar.

- Havells entered Solar Business.
- Havells re-launched Brand- Standard.
- Havells entered Personal Grooming Business
- Havells entered Water Purifier Business.

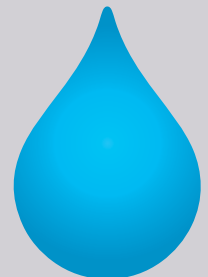
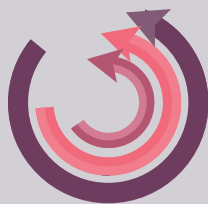

OUR R&D, CENTER FOR RESEARCH AND INNOVATION

Havells focuses on innovation as one of the main pillars for growth. An ongoing research based on new ideas; inventions gives our work force a new direction towards technical progress.

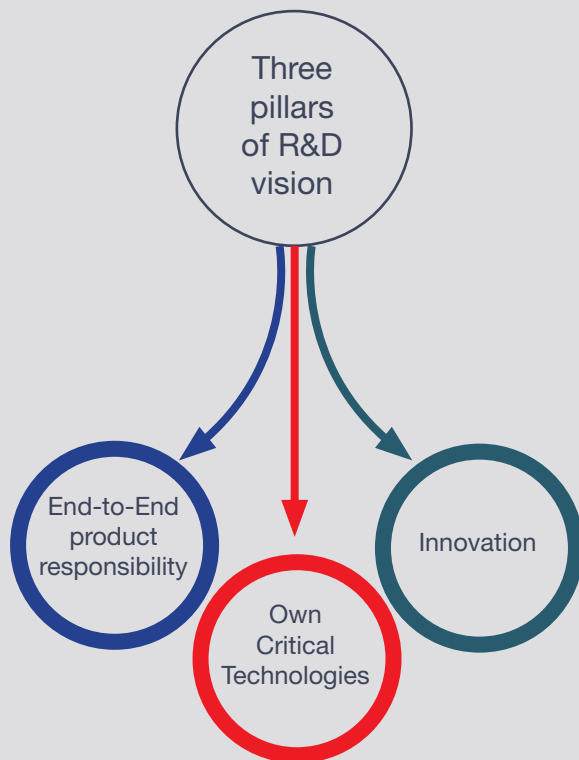

CRI has set its vision on building world-class products owing to all critical technologies – to establish HAVELLS as a global FMEG Company, acclaimed for delivering unparalleled consumer excellence.

We take complete ownership of new product – design and development, for production in our state-of-the-art plants and delivery to delight end consumers.

Our prime objective is to democratize technology – driven customer – centric Innovations through amplified collaborations between product verticals and technology horizontals.

Please stay tuned for key snippets from the exciting journey ahead.

32% of our R&D spending is directed towards environmental and social benefit products and technologies



AWARDS & RECOGNITIONS



QTRON | MOULDED CASE CIRCUIT BREAKER



Designed to cater the need for
a new beginning in electrical distribution.



Index

Salient Feature	10
Appearance and Markging	11
Range Feature	12
Technical Data Sheet	13
Accessories	14
Temperature Derating	19
Power Dissipation	19
Time Trip Curve	20
Application	22
Overall Dimension	24
Upcoming MCCB	30



Salient Features

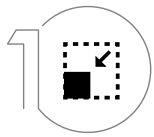

Compact Footprint



Current Limiting, outstanding single break

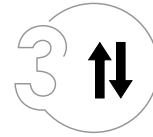

Line-Load Reversibility



Reliable breaking performance, Ics=100% Icu

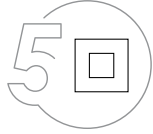

Class II Insulation



Quick Toggle, Trip free mechanism



Positive Isolation

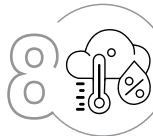

Suitable for harsh Environments



Trip Intelligence

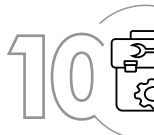

Easy and Field Installable accessories



Harsh Environment

- 50 °C Ambient
- 50% Relative Humidity
- Pollution Degree III

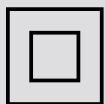

Extra Safe Insulation

- Superior materials
- Oversized insulation



Reliability

- Rugged construction
- Designed with statistical margins
- Minimum downtime in installations



Safety

- Responds quick against faults
- Dedicated protection covers





Appearance and Marking

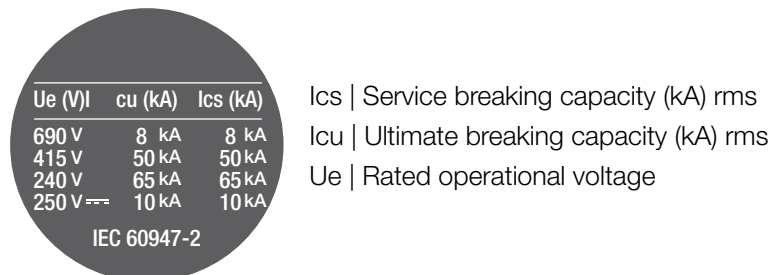
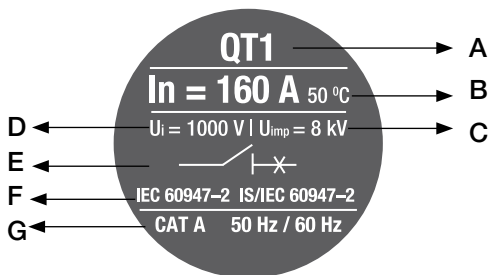
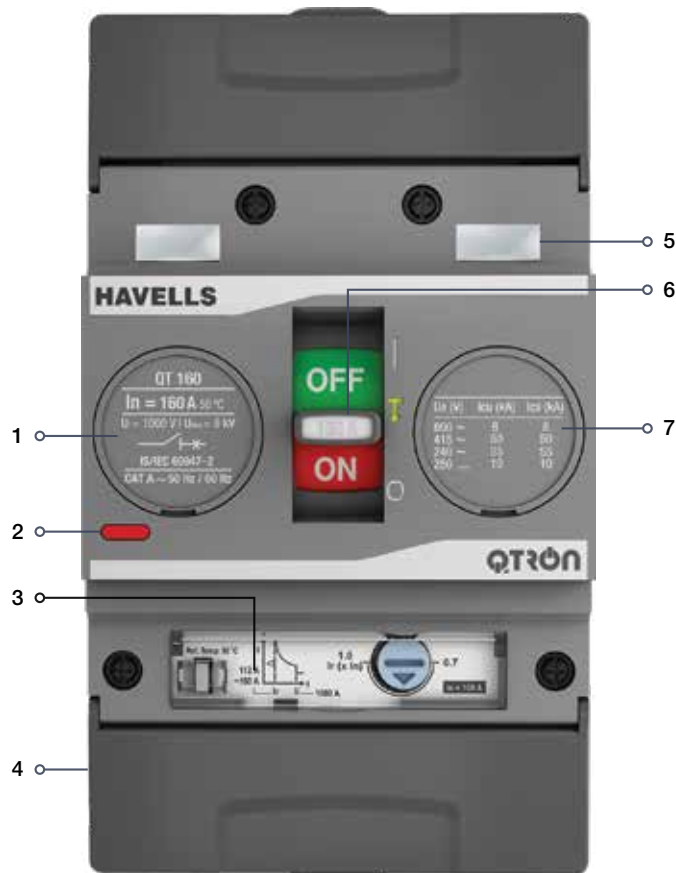

1. Standard Characteristics
2. Push to Trip button
3. Trip Unit - TMTU / ETU
4. Dedicated terminal cover, finger protection
5. Accessories indication window
6. Operating Handle, with rated current label
7. Breaking Capacity (kA)

A | MCCB Type/Frame Size

B | In - Rated Current (Amperes)

C | U_{imp}, Rated impulse withstand voltage

D | U_i, Rated Insulation Voltage

E | Symbol - Circuit breaker suitable for isolation

F | Relevant Standard

G | Utilization Category





Range Features

- Wide Product Range: 16 A – 160 A
- Reference Standard: IEC 60947-1&2
- High insulation voltage up to 1000 V
- High operation voltage up to 690 V
- High Mechanical and electrical life
- Optimal space utilization in panel in relation to breaking capacity
- Enhanced discrimination and cascading capability
- Flexible for installation

QT 160		
Protection Release	Current Rating (A)	Breaking Capacity (kA) Ics = 100% of Icu @ 415 V AC
Thermal Magnetic	16 A, 20 A, 25 A, 32 A, 40 A, 50 A, 63 A, 80 A, 100 A, 125 A, 160 A	36 kA, 50 kA



Trip Intelligence

QTRON circuit breakers are precisely designed to protect against electrical faults, isolate and switch circuits in low voltage distribution networks. The modern generation of circuit breaker's fault protection is achieved by a combination of the devices unique current limiting properties and integrated protection devices generally termed as "trip units". This performs the brain power function in a circuit breaker, designed to protect circuits and/or the equipment connected to these circuits/load.

Devices available in a current range of 16 A to 160 A as three & four pole execution.

QT 160 - Thermal Magnetic Trip Units

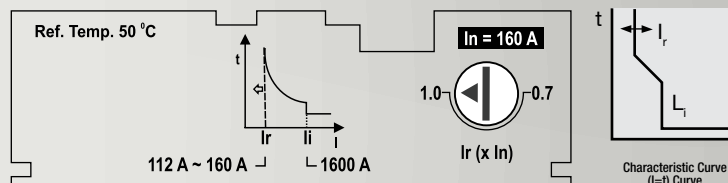

Rated Current, I_n (A)	16	25	32	40	50	63	80	100	125	160	
Overload Protection (Thermal), I_r											
Fixed Type (FT)	$1.0 \times I_n$	16	25	32	40	50	63	80	100	125	160
Adjustable Type (AT)	$0.7 \times I_n$	11.2	17.5	22.4	28	35	44.1	56	70	87.5	112
	$1.0 \times I_n$	16	25	32	40	50	63	80	100	125	160
Short Circuit Protection (Magnetic), I_i											
Fixed Type (FM)	400	400	400	400	500	630	800	1000	1250	1600	
Neutral Protection											
4P 4T (N=100%)	= I_r	= I_r	= I_r	= I_r	= I_r	= I_r	= I_r	= I_r	= I_r	= I_r	
4P 3T (N=0%)	Not Protected										



Technical Data Sheet



Frame		QT 160	
Rated uninterrupted current (@ 50 °C)	A	16 A, 20 A, 25 A, 32 A, 40 A, 50 A, 63 A, 75 A, 80 A, 100 A, 125 A, 160 A	
Poles	No.	3P / 4P	
Rated Operational Voltage (Ue)	V AC @ 50 Hz	690 V	
Rated Insulation Withstand Voltage (Ui)	V	1000 V	
Rated Impulse Withstand Voltage (Uimp)	kV	8 kV	
Suitability for Isolation		Yes	
Utilization Category		A	
Pollution Degree		3	
IP Protection		IP40	
Breaking capacity levels		E	F
Rated ultimate short-circuit breaking capacity, Icu (kA)	230 V /240 V AC	55 kA	65 kV
	400 V /415 V AC	36 kA	50 kV
	690 V AC	6 kA	8 kA
Rated service short-circuit breaking capacity, Ics (kA)	230 V /240 V AC	100%	
	400 V /415 V AC	100%	
	690 V AC	100%	
Endurance	Mechanical	25000	
	Electrical at In and 415 V AC	10000	
	Electrical at In/2 and 415 V AC	20000	
	Electrical at In and 690 V AC	5000	
	Electrical at In/2 and 690 V AC	10000	
Endurance (On-tripped operations)	Mechanical	10000	
Trip Unit			
Thermal Magnetic	Long time [LT]	(0.7 - 1.0) x In	
	Instantaneous [INST]	16 - 32 A: 400 A, 40 - 160 A: 10 x In	
Installation & Dimension			
Mounting	DIN Rail	Yes	
	Fixed	Yes	
Connection	Front	Yes	
	Rear	Yes	
Dimensions (mm)			
W x H x D	3 pole	(75 x 130 x 70) mm	
	4 pole	(100 x 130 x 70) mm	
Weight (g/kg)	3P/4P	800 g / 1 kg	



Internal Accessories

Auxiliary Switch (AXT), Alarm Switch (ALT)

Indicates the status of circuit breaker contacts from a remote position as well as using for electric locking.

Auxiliary Switch (AXT)

- Indicating ON/OFF status of circuit breaker.
- Status is OFF when TRIP.
- Consists of C contact.

Alarm Switch (ALT)

- Activated when the circuit breaker has tripped due to an overload, short circuit or ground fault, excepting manual ON/OFF operation.
- Return to original state, when circuit breaker reset.
- Consist of C contact.

Auxiliary + Alarm Switch (AAT)

- Combined auxiliary switch (AXT) and Alaram Switch (ALT)

Double Auxiliary Switch (2xAXT)

- Combined auxiliary switch (AXT)



Shunt Trip (SHT)

Remotely trip circuit breakers by voltage shunt trip (SHT) device.

Operation Condition:

- $U \geq 0.7 \times U_n$ (Apply more than 70 % of the rated voltage.)
- n case of impulse type voltage, apply more than 20 ms

Rated Voltage and Characteristic

Rated Voltage (U_n)		Power Consumption	
		VA (W)	A (A)
DC	24 V	1.27 W	53 A
	48 V	0.67 W	14 A
	60 V	1.44 W	24 A
	110 V	3.08 W	28 A
AC (50 Hz / 60 Hz)	110 V	1.45 W	13 A
	230 V	1.83 W	8 A
	415 V	4.67 W	11 A
Rated Operational Voltage	0.7 - 1.1 X U_n		
Operating Time	50 ms		



Undervoltage Release (UVR)

In case circuit voltage is less than the reference value, the circuit breaker will not trip or ON. If circuit voltage falls less than 35 % of Rated voltage (U_n), UVR initiates a trip automatically to prevent damage to the load.



Opening Conditions:

- Operating characteristics are based on IEC 60947-2 standard criteria.
- Trip condition: $U \leq 0.35 \times U_n$
- Time Delay: 500 - 1,000 ms (Up to 250 AF)
- No Trip condition: $U \geq 0.7 \times U_n$
- In $U = 0.35 \times U_n - 0.7 \times U_n$ interval, circuit breaker can be tripped but, does not warrant the operation.

Closing Conditions:

- For the circuit breakers installed with UVR, when voltage is not applied to the UVR, the circuit breaker is possible to OFF/RESET but can not be ON.
- Voltage must be applied at UVR for closing (ON).
- Closing condition: $U \geq 0.85 \times U_n$
- Be sure not to use UVR for the electrical interlock system.

Rated Voltage and Characteristic

Rated Voltage (U_n)		Power Consumption	
		VA (W)	A (A)
DC	24 V	0.96 W	40 A
	48 V	1.1 W	22.7 A
	110 V	0.66 W	6 A
AC (50/60 Hz)	110 V	0.72 W	6.6 A
	230 V	2.58 W	11 A
	415 V	3.65 W	9 A
Operating Inception Voltage	In the Case of Trip	0.35 - 0.7 X U_n	
	In the Case of Closing	0.85 X U_n	
Rated Operational Voltage	0.85 - 1.1 X U_n		
Operating Time	500 - 1000 ms		



External Accessories

Locking Device

Rotary Handle

Rotary handle is the device to check for MCCB's ON/OFF/TRIP status from outside of switchgear. There are two types of rotary handle-extended type and direct type. All the rotary handles provide panel door locking and handle locking function by rotating clockwise the rotary handle, the circuit breaker operates "ON". Each rotary handle is divided into these three types the upper line, the right line, and the left line-according to attachment direction of MCCB.

Direct Rotary Handle

- 16 A - 630 A : Attach handle directly to the circuit breaker.
- 16 A - 630 A : Attach handle to the door of switchgear.

Extended Rotary Handle

Suitable for the case where the distance between circuit breaker and door switchgear is long. The handle is attached to the door of switchgear so there is no trip-button function.

Padlock Device (PLD)

This device is used for locking the handle of circuit breakers to OFF position by using padlock. Key lock is applicable upto 3 EA and not be supplied additionally.

- Fixed Padlock Device
- Removal Padlock Device

keylock are as below.

Type	Application	Padlock Diameter
		5 mm to 8 mm

DIN-Rail mounting kit

QT160 A breakers can be installed on (symmetric) 35 mm DIN profile by using an adapter. The DIN-Rail adapter is mounted on the back of the breaker.

Spreader Terminal Kit

Straight Spreader Terminal

- Used to meet the size of the cable or standards of the switchgear. (No change of the pitch between the poles)

Extended Sprader Terminal

- Used to extend the insulation distance. (Extension of the pitch between the poles)

Terminal Cover

Terminal cover is the device to insulate circuit breaker terminal from the outside for safety. It is possible to apply IP40 as protection degree of power parts. The connecting method is of long type which is suitable for front connection using wires, busbar.

Phase Barrier

Insulation barrier is used for preventing short-circuit fault due to dielectric breakdown between circuit breaker terminals. It improves the performance of terminal phase-to-phase insulation if installed at groove between the terminal of two circuit breakers. It can be easily assembled after the installation of the circuit breaker. In addition, it is used in terminal cover.



Accessories

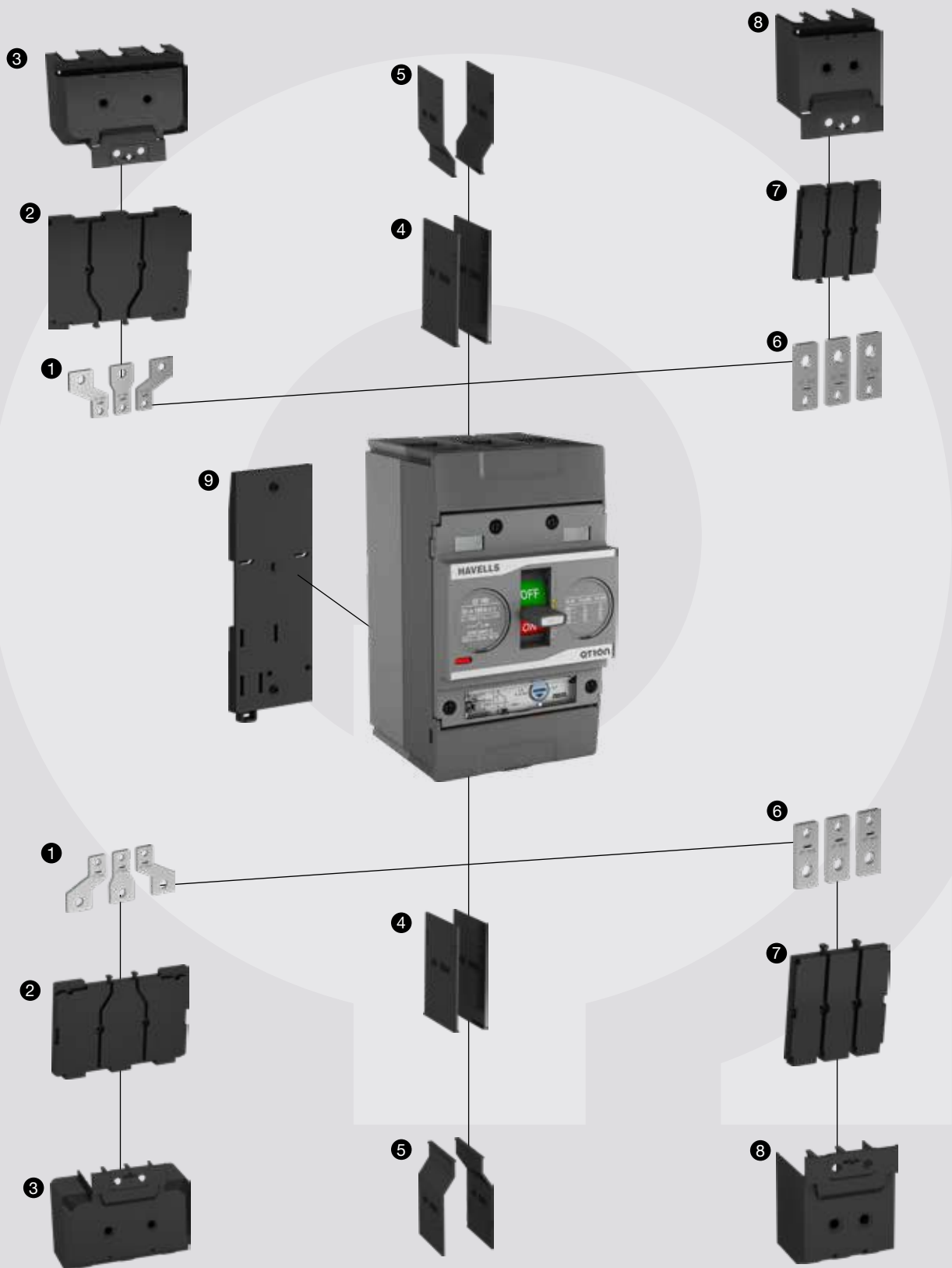

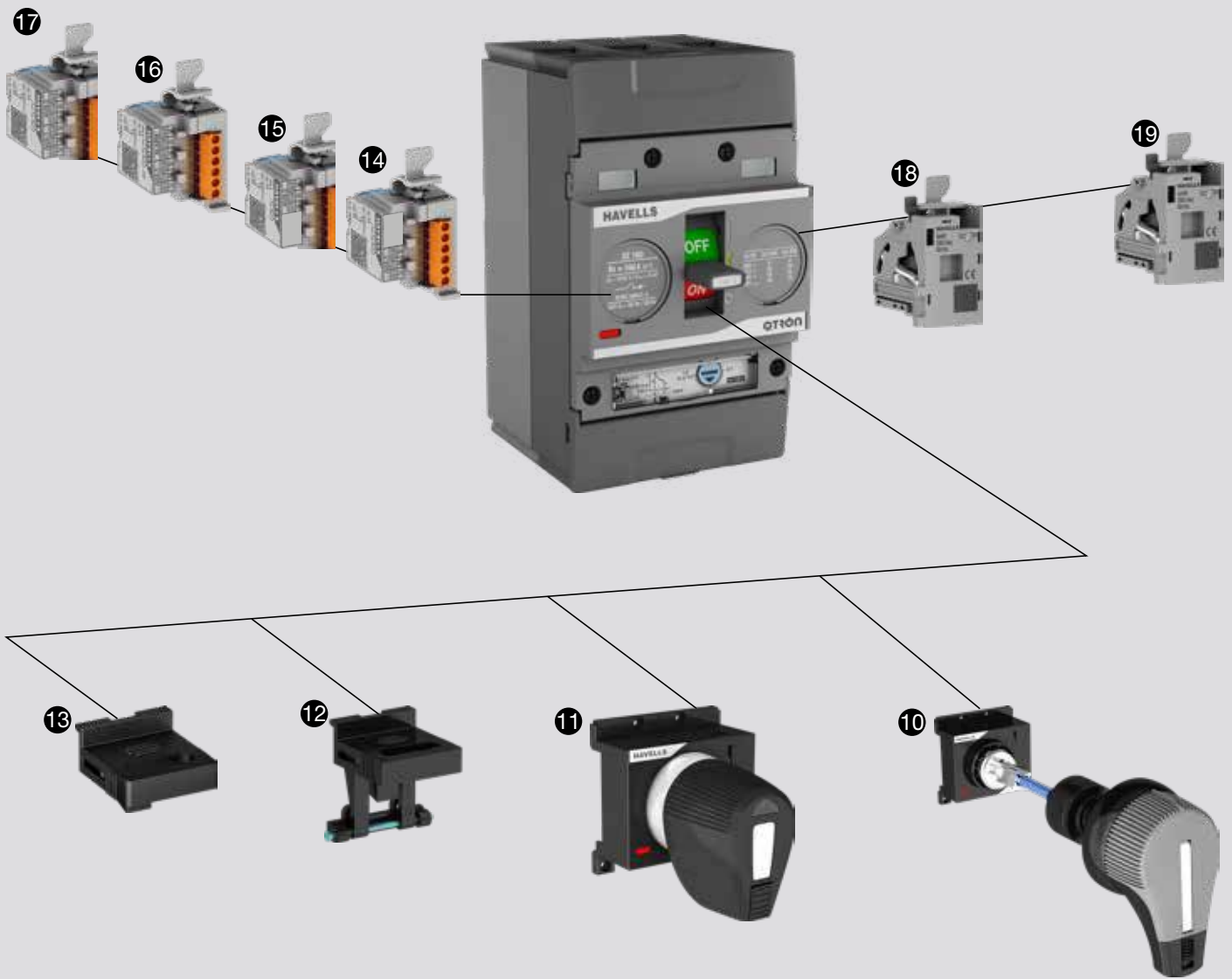

- | | | |
|------------------------------------|---|-------------------------------------|
| 1. Extended Sprader Terminal | 7. Straight Back Plate | 13. Removable Padlock |
| 2. Extended Back Plate | 8. Straight Terminal Cover | 14. Auxiliary Switch (AXT) |
| 3. Extended Terminal Cover | 9. DIN Mounting Plate (only for QT 160) | 15. Alarm Switch (ALT) |
| 4. Straight Phase Barrier | 10. Extended Rotary Handle | 16. Auxilliary + Alarm Switch (AAT) |
| 5. Extended Straight Phase Barrier | 11. Direct Rotary Handle | 17. Double Auxiliary Switch |
| 6. Straight Sprader Terminal | 12. Fixed Padlock | 18. Shunt Trip (SHT) |
| | | 19. Undervoltage Release (UVR) |



Internal Accessories

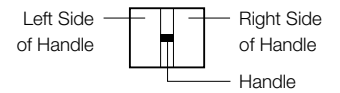

Type	Pole	SHT				UVR			
		AUX	2 AUX	ALT	AAT	AUX	2 AUX	ALT	AAT
QT 160	3/4								

AUX: Auxiliary Switch		ALT: Alarm Switch		SHT: Shunt Trip	
2AUX: Double Auxiliary Switch		AAT: Auxiliary Alarm Switch		UVR: Under Voltage Release	



Temperature Derating

The ambient operating temperature directly influence the current carrying properties of MCCB. QTRON QT MCCB has been calibrated at ambient temperature 50 °C. If the ambient temperature differs from 50 °C, the overcurrent characteristics of MCCB should be changed. If the ambient temperature increases from 50 °C, the electrical and/or mechanical properties of MCCB is deteriorated. It will also speed up the reaction time of bimetal action, when ambient operating temperature is higher than its rated ambient temperature. To achieve the same reaction time of bimetal and protect the MCCB from internal damage, the rated current of MCCB must be derated according to the derating table. If the ambient temperature is less than 50 °C then the current rating is also adjusted according to derating table.

Rated Current Derating Table: QTRON QT MCCB

FRAME	Rated Current (A)	20 °C	25 °C	30 °C	35 °C	40 °C	45 °C	50 °C	55 °C	60 °C	65 °C	70 °C
QT160	16	19	18	18	18	17	17	16	16	15	15	14
	20	24	23	22	22	21	21	20	20	19	19	18
	25	29	28	28	27	26	26	25	24	24	23	23
	32	37	36	36	34	34	33	32	31	30	30	29
	40	46	45	44	43	42	41	40	39	38	37	36
	50	57	56	55	54	52	51	50	49	48	46	45
	63	72	71	69	68	66	65	63	62	60	59	57
	80	92	90	88	86	84	82	80	78	76	74	72
	100	115	113	110	108	105	103	100	98	95	93	90
	125	143	139	137	134	131	128	125	122	119	115	111
	160	187	182	177	173	169	165	160	155	150	145	140

Power Dissipation

Power dissipation table of QTRON MCCB consists of resistance per pole. It is used as general indication of new MCCB. The power dissipated in each pole depends upon current flowing through MCCB and resistance per pole of MCCB. The table indicates the power dissipation per pole of MCCB derived from maximum current rating at 50 Hz / 60 Hz. The total power loss of MCCB is three times the power dissipation per pole at 50 Hz / 60 Hz. It is used to determine total rise in switchboard temperature where the MCCB is installed. Measurement and calculation of power loss has been done according to Appendix G of standard IEC 60947-2.

Rated Current (A)	QT1 (QT160 Frame)	
	R/Pole (mΩ)	P/Pole (W)
16 A	10 mΩ	2.56 W
20 A	10 mΩ	4 W
25 A	4.8 mΩ	3 W
32 A	4.8 mΩ	4.92 W
40 A	2.7 mΩ	4.32 W
50 A	1.7 mΩ	4.25 W
63 A	1.7 mΩ	6.75 W
80 A	0.8 mΩ	5.12 W
100 A	0.7 mΩ	7 W
125 A	0.5 mΩ	7.81 W
160 A	0.5 mΩ	12.8 W



QT 160 Trip Time Curve

QTRON QT1 TM Trip Units

16 A - 20 A

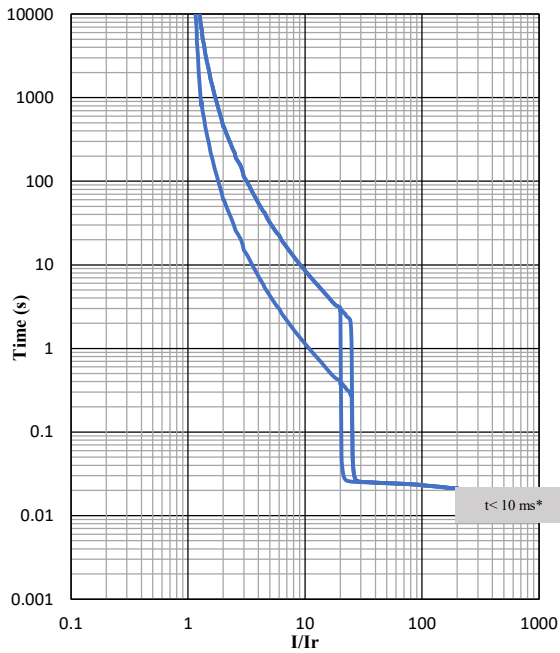

25 A - 32 A

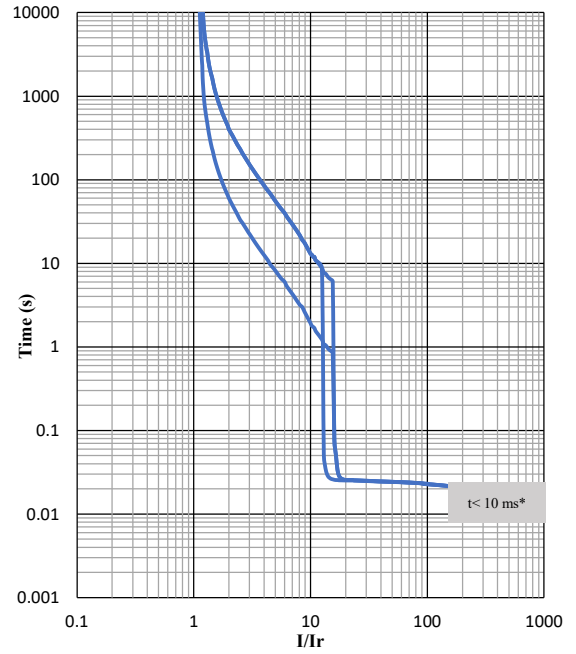

40 A

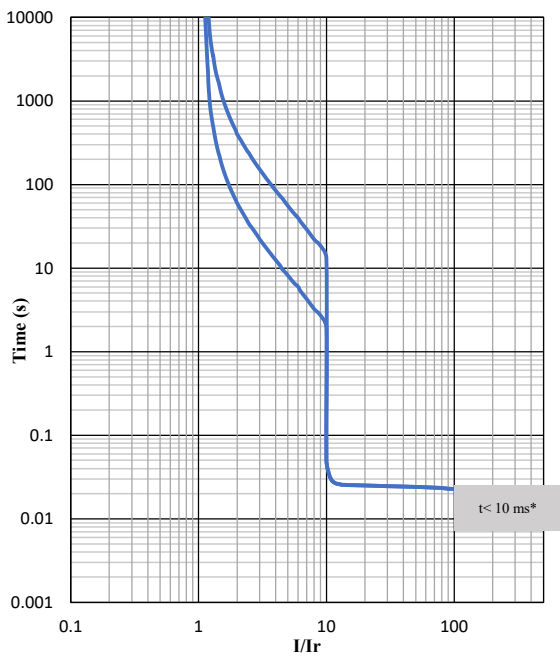

50 A - 63 A

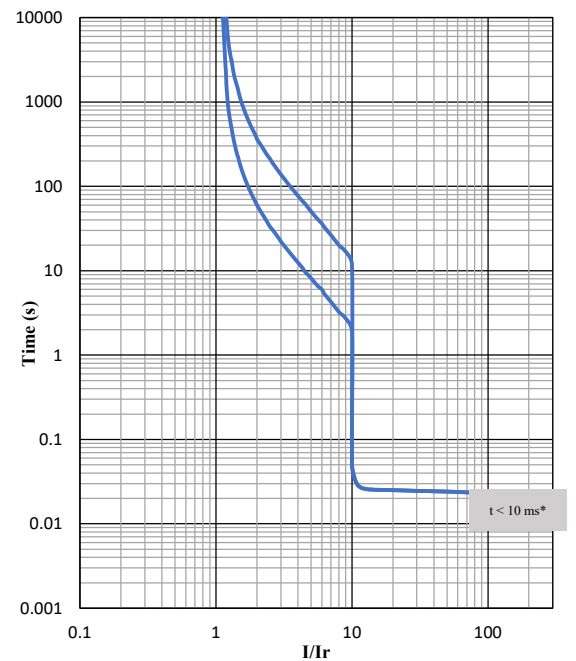

QT 160 Trip Time Curve

QTRON QT1 TM Trip Units

80 A

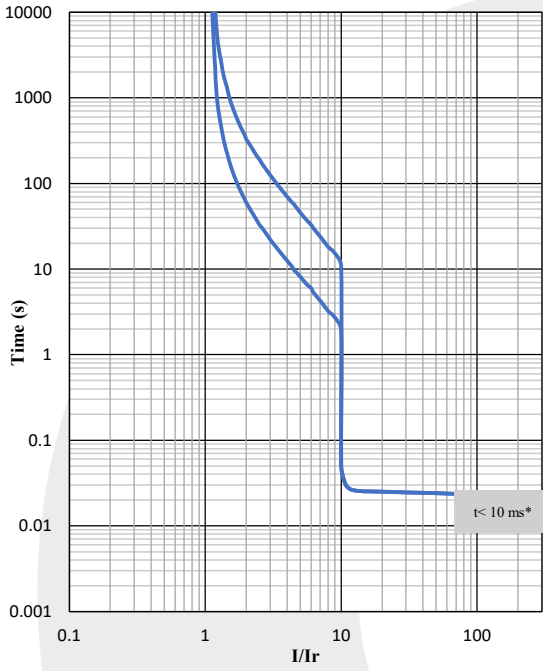

100 A

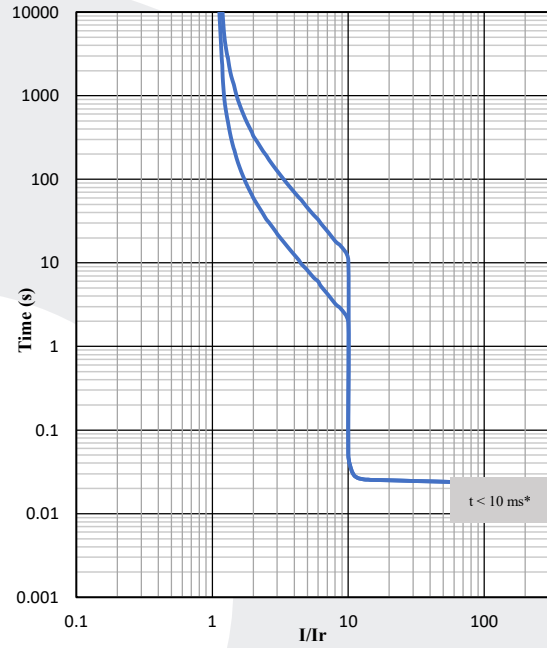

125 A - 160 A

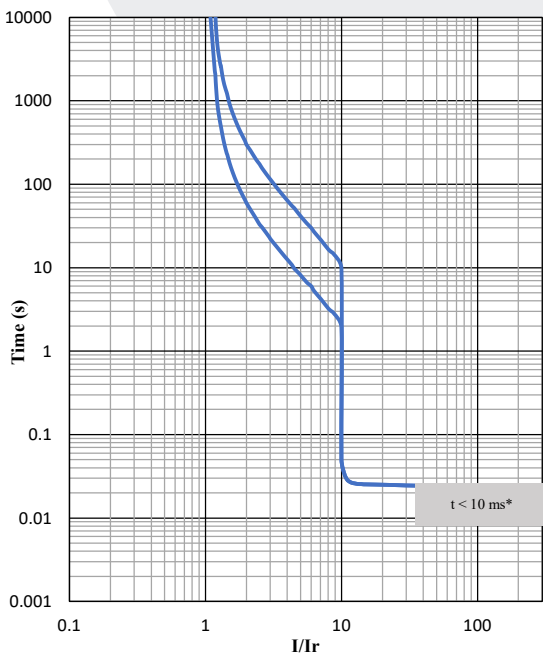

Applications

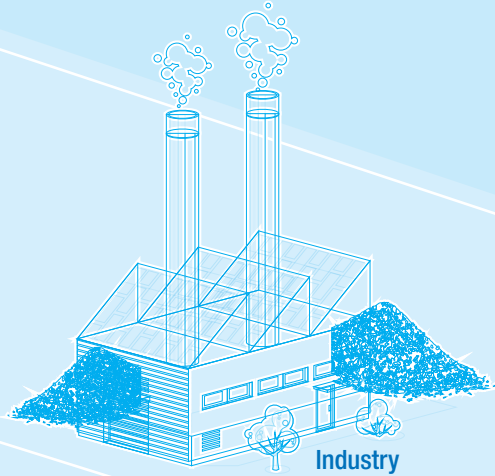

Industry



Commercial Building

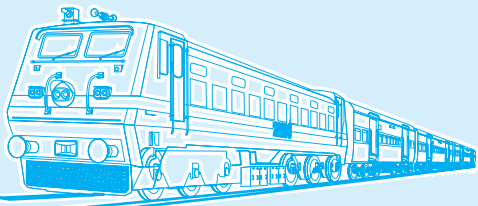

Railways

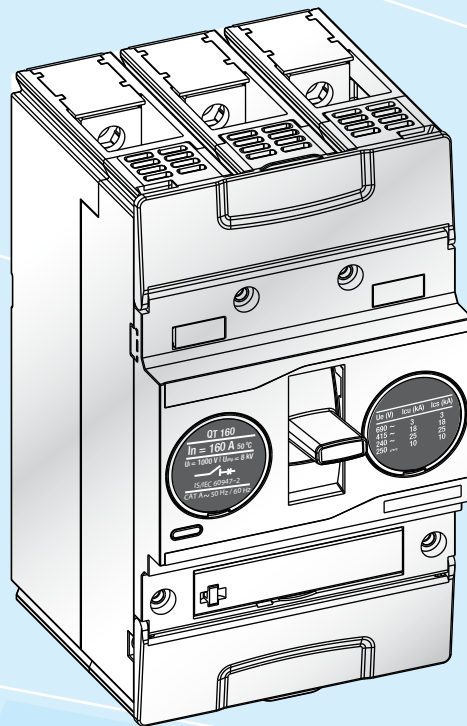

Residential Building

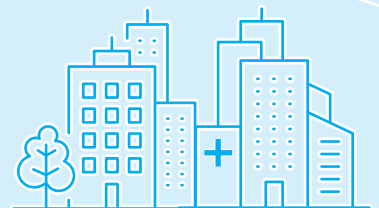

Hospital

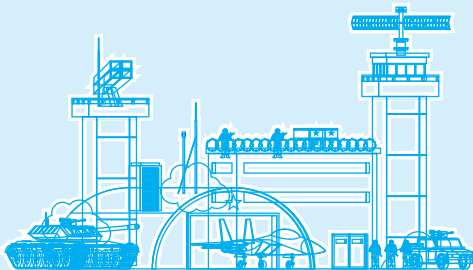

Defence

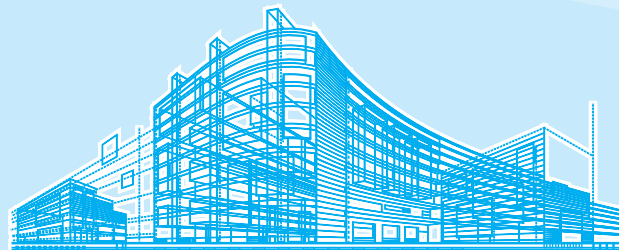

Shopping Mall





QT 160 Drawings

Standard breaker 3P & 4P

Dimensions are in (mm)

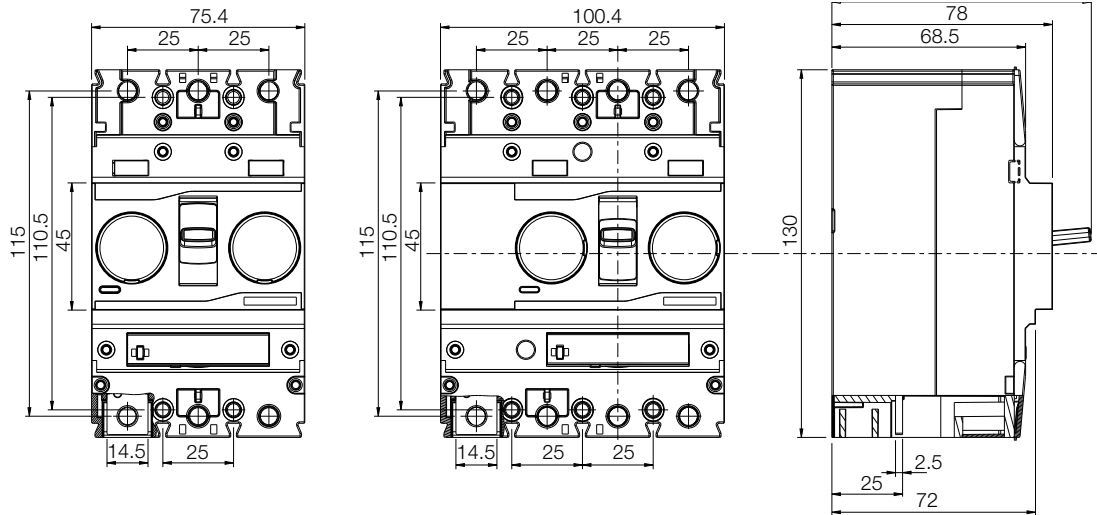

Breaker + Rear Insulating plate @ top with Z Spreader 3P & 4P

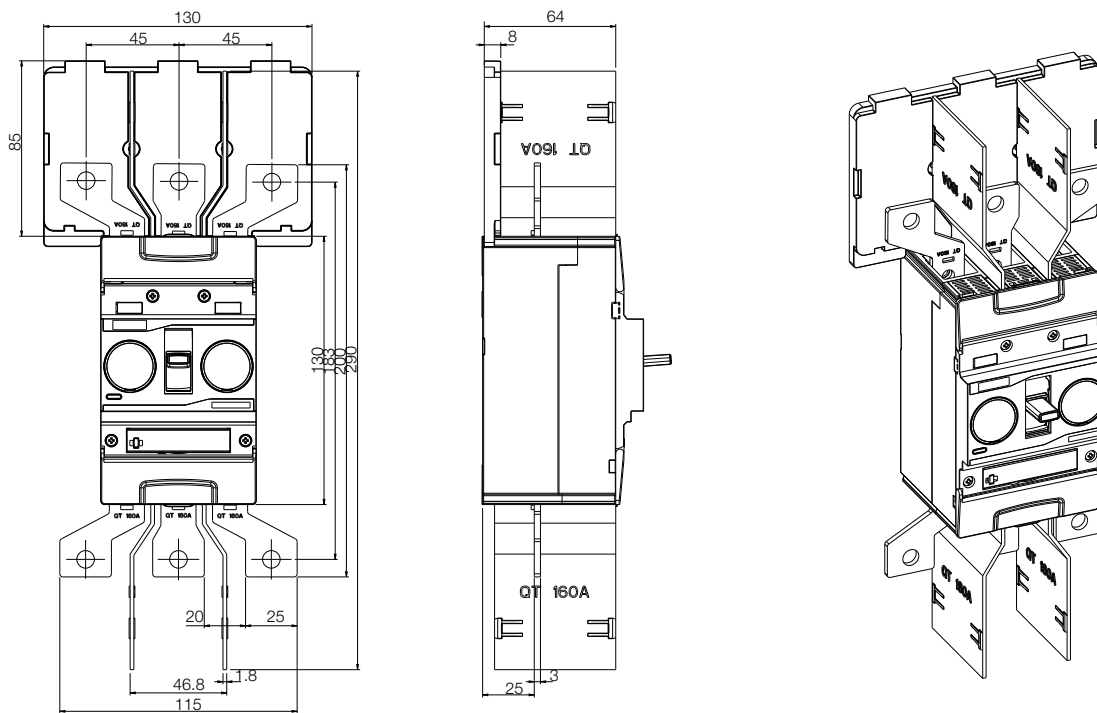

DIN Rail Mounted, Standard Breaker 3P & 4P

DIN Rail Installation

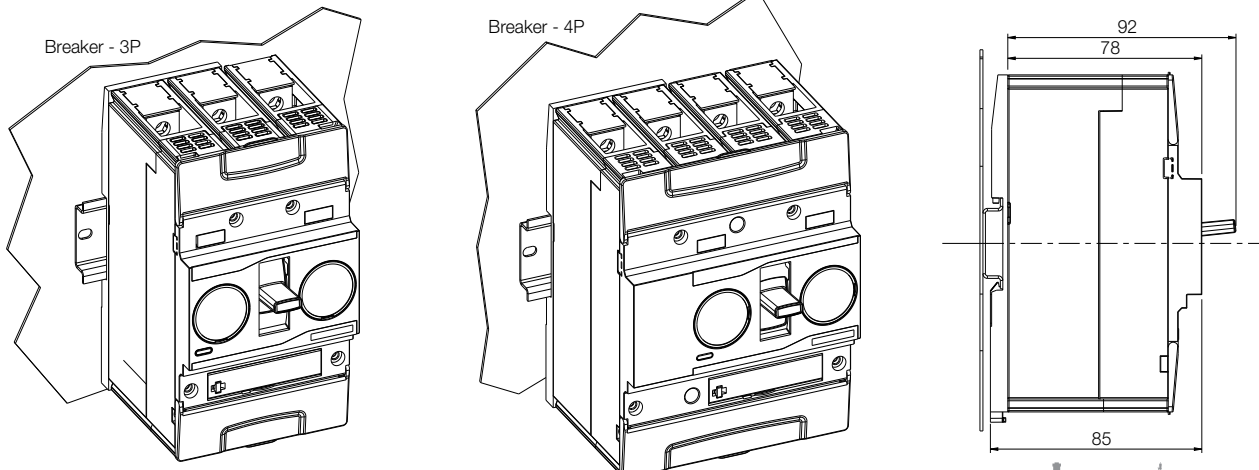

Mounting Plate Holes 3P & 4P

Dimensions are in (mm)

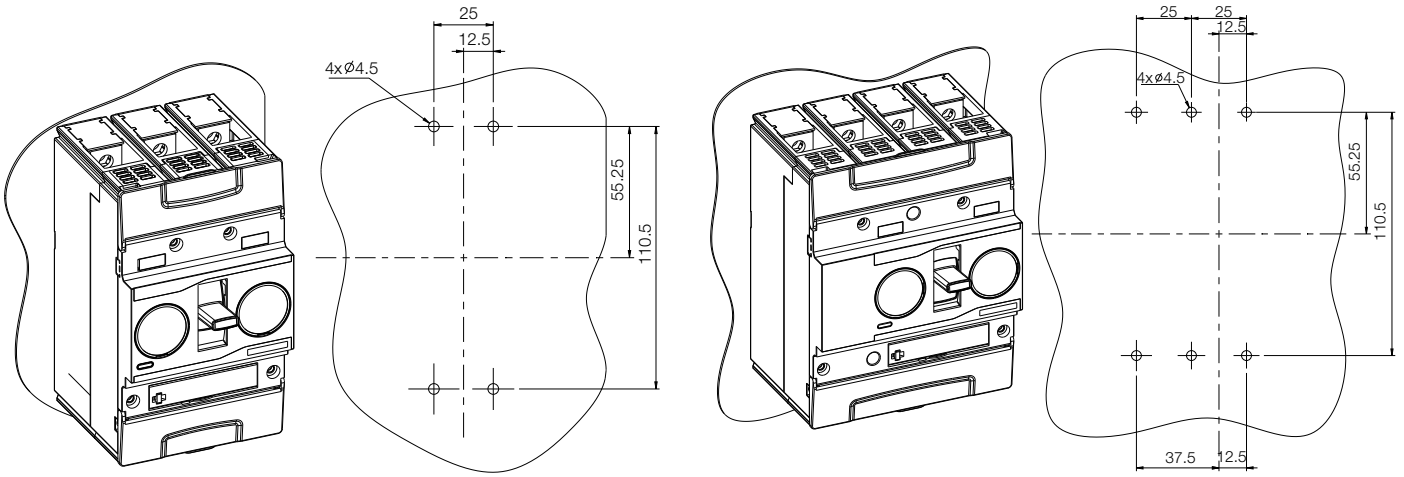

Front Panel Cutout 3P & 4P

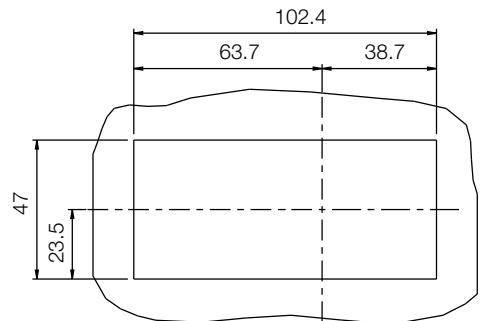
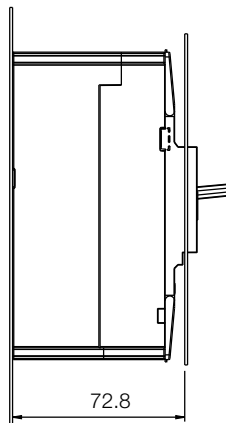
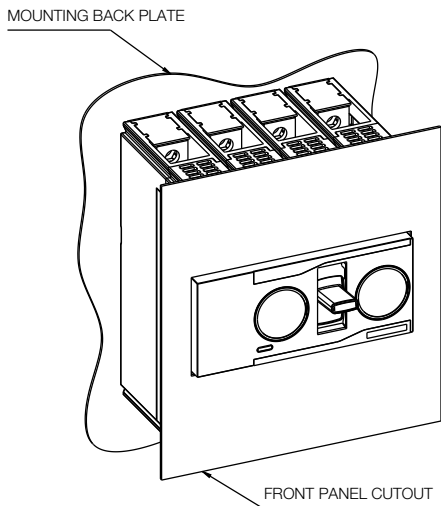
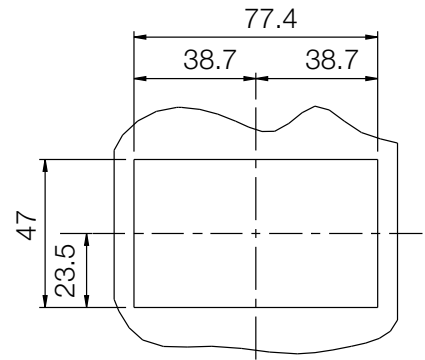
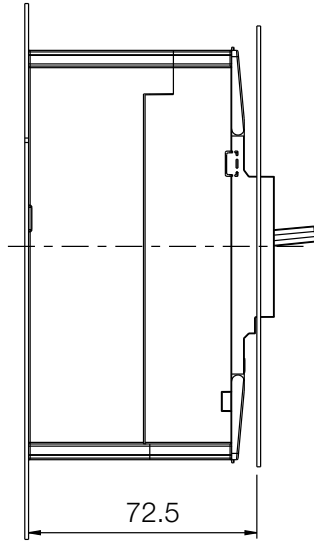
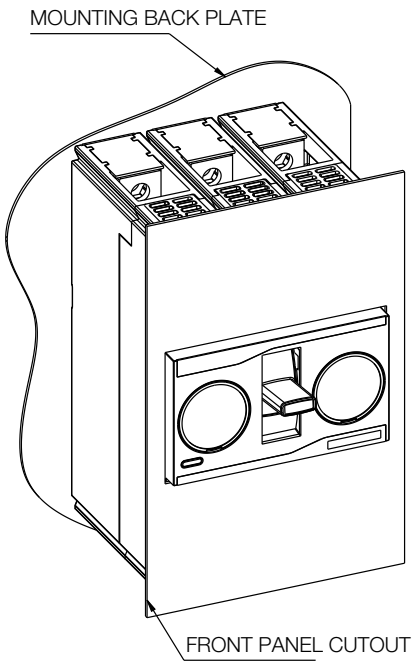

Breaker - 4P



Breaker + Fixed Padlock 3P & 4P

Dimensions are in (mm)

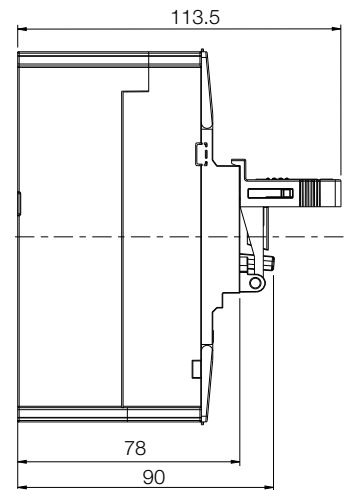
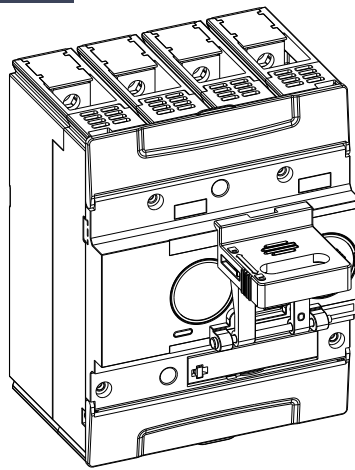
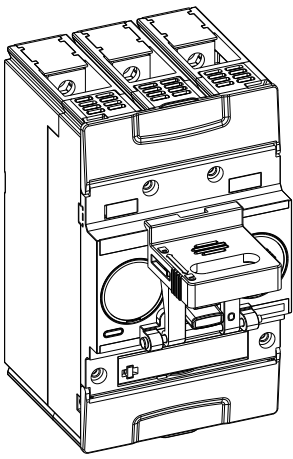

Breaker + Removal Padlock 3P & 4P

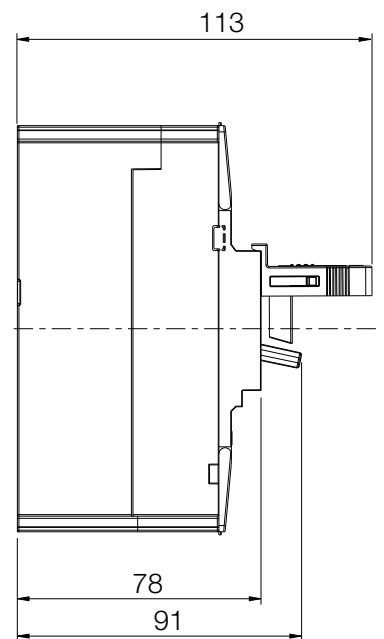
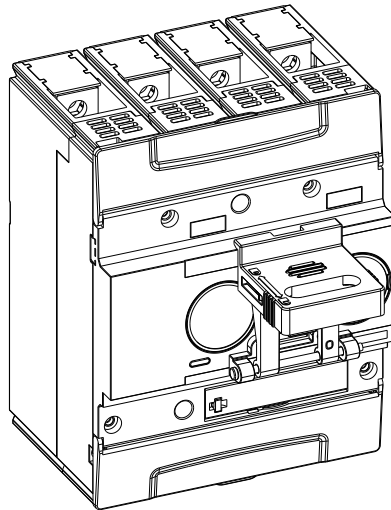
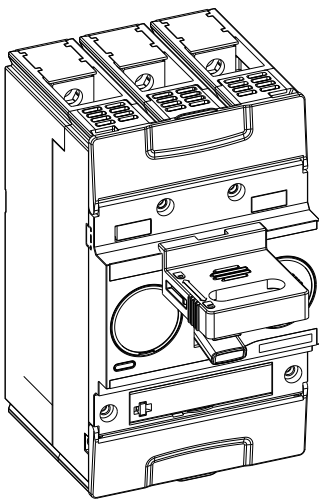

Breaker + Terminal Shield 3P & 4P

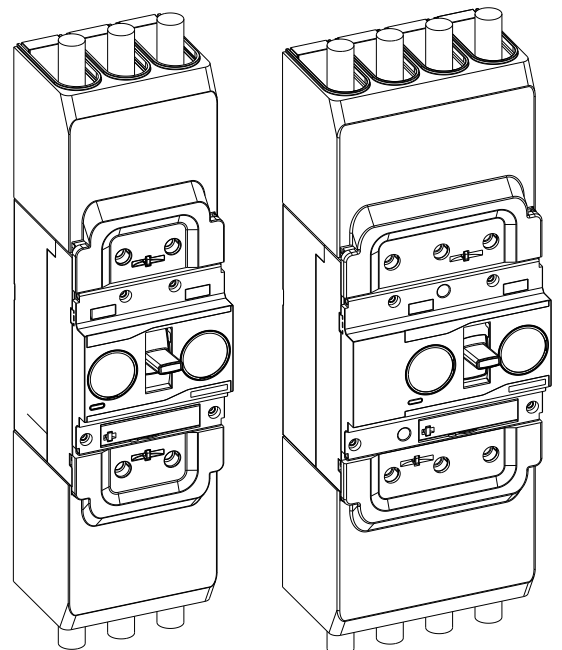
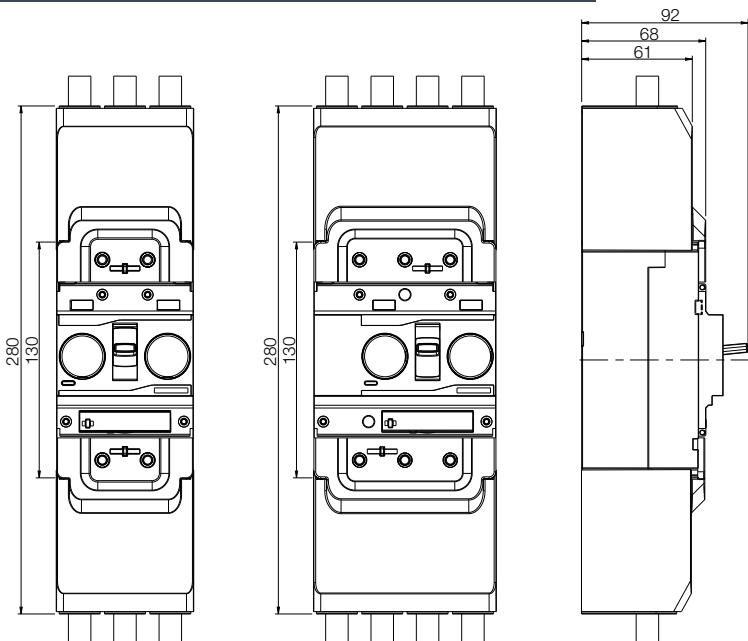

Breaker + Direct Rotary Handle 3P & 4P

Dimensions are in (mm)

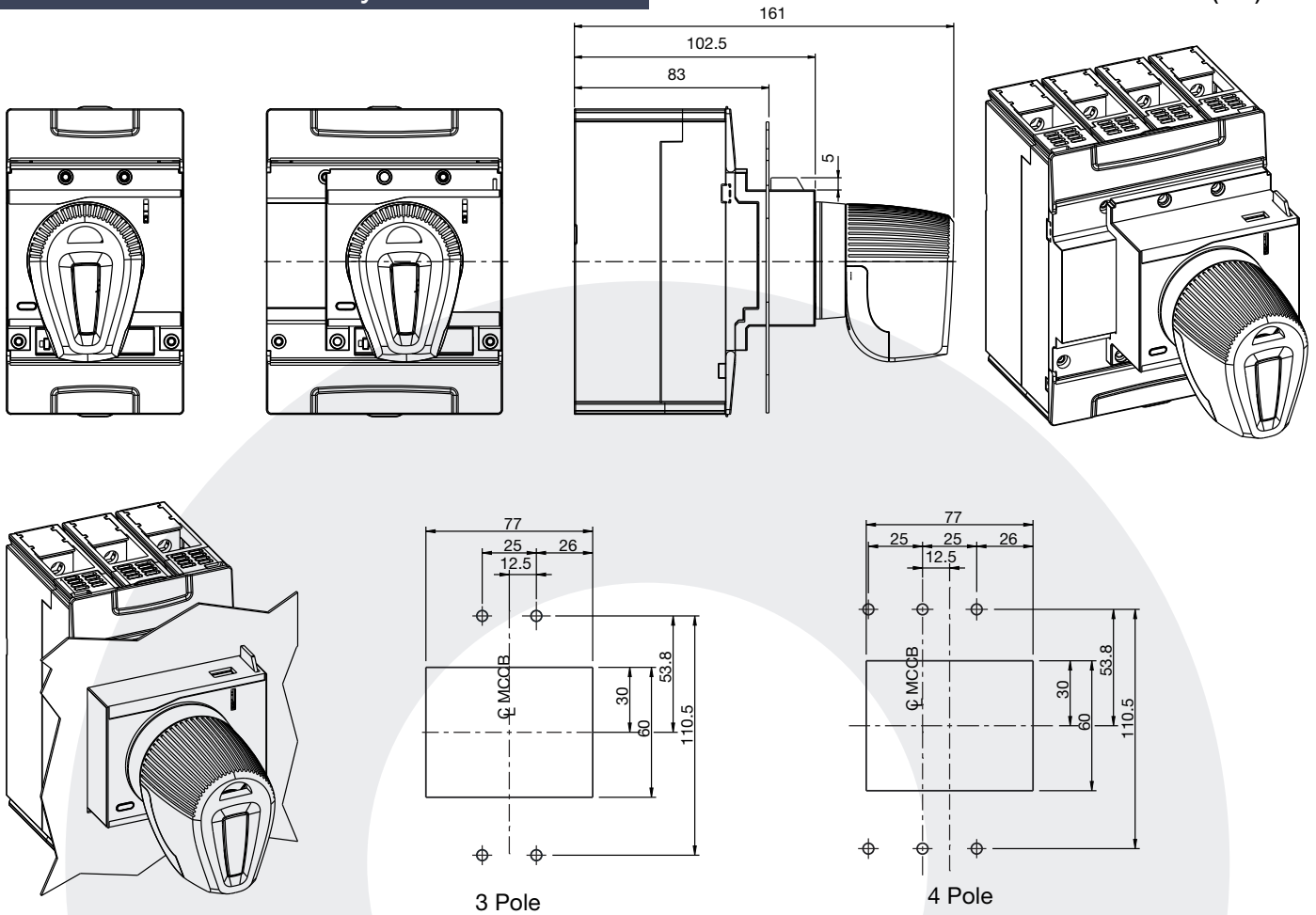

Breaker + Extended/Panel Door mount Rotary Handle 3P & 4P

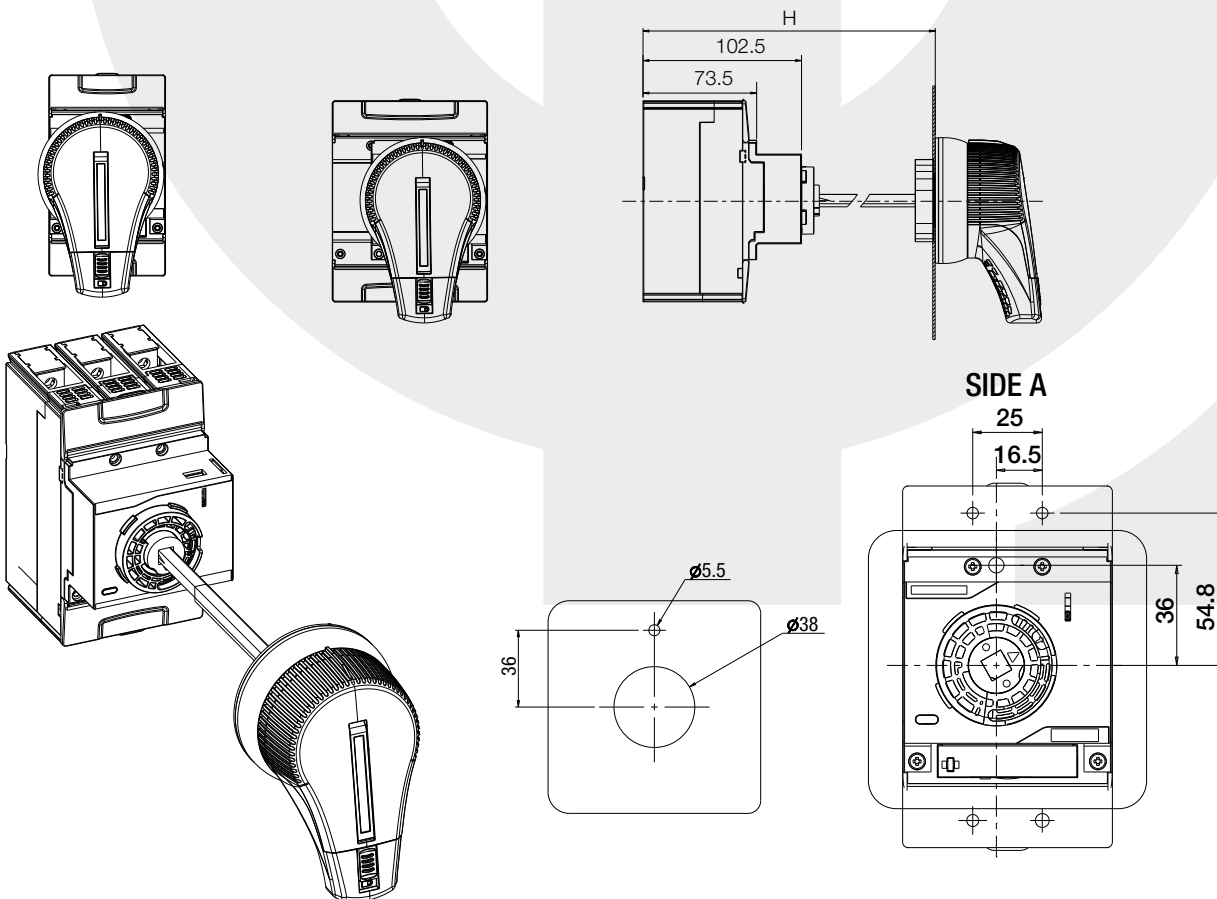

Breaker + Rear Insulating plate @ top with S spreader 3P & 4P

Dimensions are in (mm)

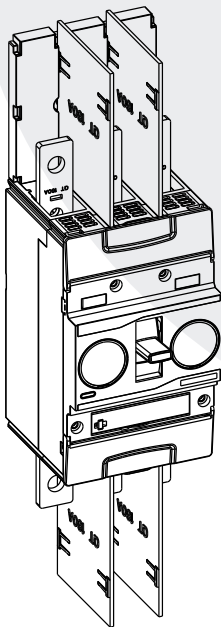
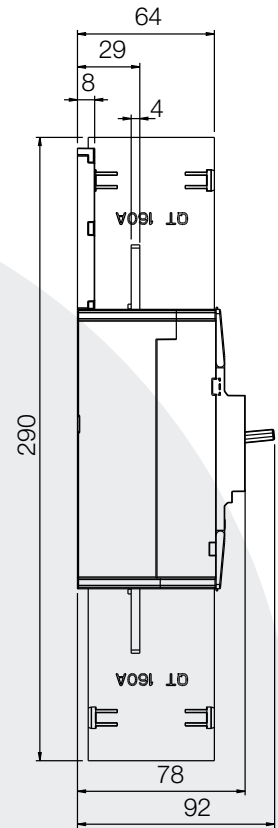
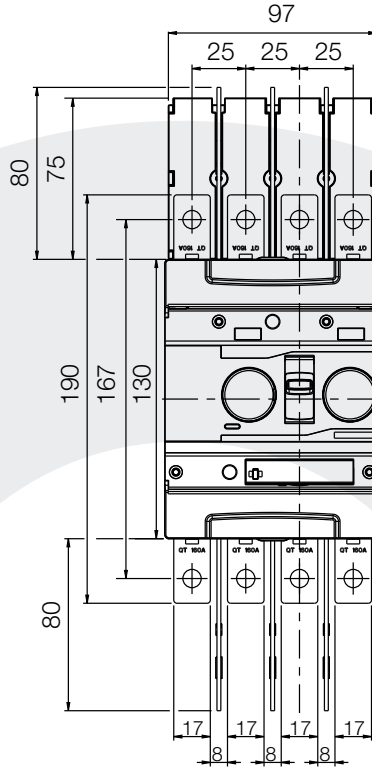
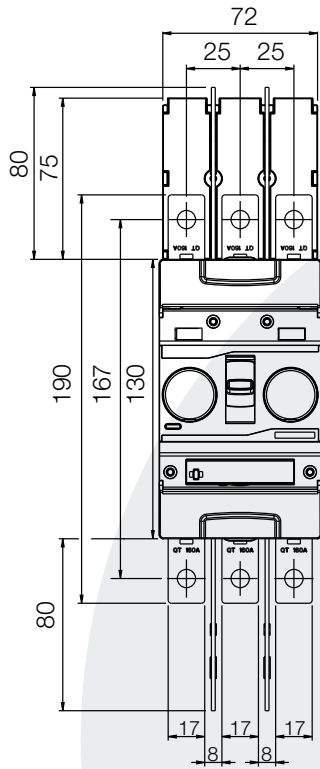

Breaker - 3P

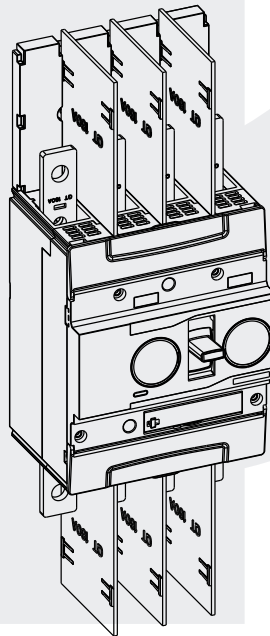

Breaker - 4P



MCCB Enclosure

Dimensions are in (mm)

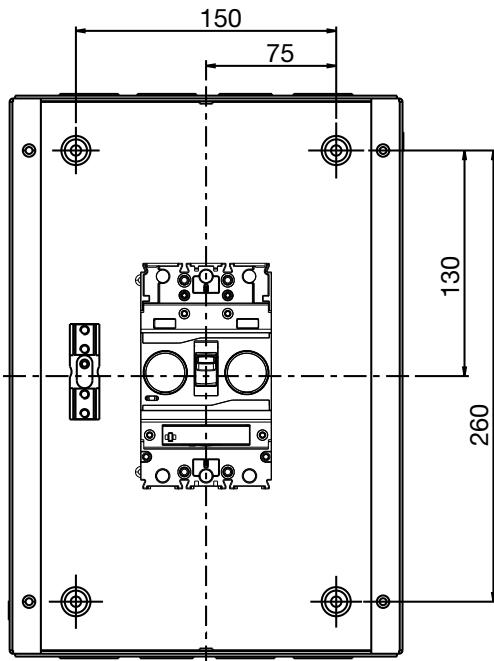
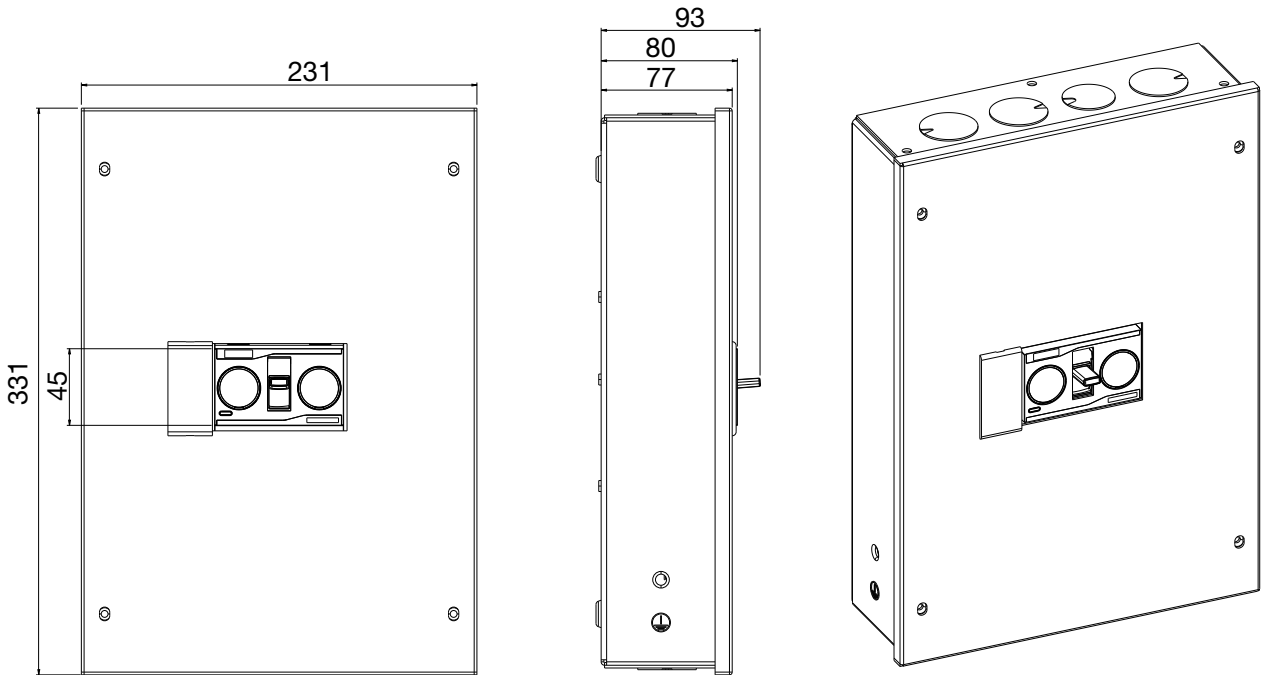

Upcoming ...

Digital Display Communication Compatible with cloud connectivity

Breaking Capacity up to 70 kA , $I_{cs}=I_{cu}=100\%$

High Insulation Voltage – 1000 V

High operation voltage up to 630 V

Trip Intelligence

Thermal Magnetic - Adjustability Thermal & Magnetic

Microprocessor Base - LSI, Advance protection, metering & Communication Compatible with cloud connectivity.



QT 630

250 A - 630 A

QT 250

40 A - 250 A





REGIONAL & BRANCH OFFICES:

NORTH - REGIONAL OFFICE: Corporate Office: QRG Towers, 2D, Sector-126, Expressway, Noida-201304, Tel: 0120-3331000, Delhi: 011-47676700, 23888200, Chandigarh: 0172-4232400-401, Dehradun: 0135-6670202, Haldwani: 05946-222935/222933, Noida / Haryana: 0120-3331000, Ludhiana: 0161-4676000/24, Amritsar: 0183-5202400/401, Jammu: 0191-2478330, 2479330, Sri Nagar: 0194-2459248, Jaipur: 0141-4211000, 4211011, Jodhpur: 9214201640/41, Lucknow: 0522- 4921600/4921649, Kanpur: 0512- 6710400

EAST - REGIONAL OFFICE: Kolkata: ICC Tower, 5th Floor, 4 India Exchange Place, Kolkata-700001, Tel: 033-40129851/52, Bhubaneswar: 0674-6668101/102/103/104, Guwahati: 0361-2458923, 2134521, Siliguri: 0353-2525907, Ranchi: 0651-2244861, 2244862, 2244864, 2244868, 2244869, Jamshedpur: 0657-6542492, 09234369436, Patna: 0612-2207221, 2207222, 2207223, 2655518

WEST - REGIONAL OFFICE: 1271, Solitaire Corporate Park, Bldg. No. 12, 7th Floor, Andheri - Ghatkopar Link Road, Chakala, Andheri (East), Mumbai- 400093. Tel: 022 - 67298600-602, Ahmedabad: 079-40061111, 40060738/740, Indore: 0731-4219444/4219422, 0731-2572340, Rajkot: 0281-2481112, 2921212, Nagpur: 0712-2240932, 2242692, 2242699 Pune: 020-26056175-76, Raipur: 0771-4243400/01, Surat: 0261-2350137, 9979890137, Jabalpur: 0761-4064491, Bhopal: 0755-4271544, 0755-4011025

SOUTH - REGIONAL OFFICE: Chennai: Sigapi Achi Building, No. 18 / 3, 6th Floor, Rukmani Lakshminpathy Road, Egmore, Chennai-600008, Tel: 044-42280600, 605, Bangalore: 080-49075000, Coimbatore: 0422-4550200/282, Hyderabad: 040-27533372, 27533355, 27533632, Cochin: 0484-4099000, Calicut: 0495-4019193/4/5, Trivandrum: 0471-4015323, Vizag: 0891-6514339, Vijayawada: 0866-2546161/62/67/68/69, Madurai: 0452-4267000, Hubli: 0836-4248660, Trichy: 0431-4041005/06

Representative Offices: • Goa • Solapur • Gwalior • Kathmandu • Bhopal • Kolapur • Vadodara

Actual products may vary in colour, design, description and colour combination etc. Although every effort has been made to ensure accuracy in the compilation of the technical detail within this publication. Specifications & performance data are constantly changing.

“Copyright Subsists. Imitation of trade dress, graphics and color scheme of this document is a punishable offence.”



Havells India Ltd.

Corp Office: QRG Towers, 2D, Sector-126, Expressway, Noida-201304 (U.P.)

Ph. +91-120-3331000, Email:marketing@havells.com, www.havells.com

Customer Care No.: 08045 77 1313

Join us on Facebook at www.facebook.com/havells and share your ways to save planet!

CIN - L31900DL1983PLC016304



HAVELLS